



TECH TALK

**ARUBA INSTANT ON SOLUTIONS  
FOR SMALL & MEDIUM BUSINESSES**

## Rajanikanth Urs

SMB Leader – APJ

–Being the SMB leader for APJ in Aruba, a Hewlett Packard Enterprise Company. Responsible for driving HPE Aruba Networking solution and product vision, innovation, business growth and customer satisfaction across the SMB Networking market.



A woman with dark hair, wearing a pink long-sleeved shirt and a grey apron, stands in a greenhouse. She is looking upwards with her arms raised, touching the top of a window frame. The greenhouse is filled with various plants on shelves. The background is dark, suggesting it might be nighttime or the interior is dimly lit.

**aruba**  
Instant on

## **EVOLVING ARUBA INSTANT ON**

**SIMPLE, SECURE, NETWORKING FOR  
SMALL BUSINESS**

**Raj**

**SMB Leader - APAC**



# Agenda

- **Small Business Trends & Challenges**
- **Introducing Aruba Instant On**
- **Aruba Feature & use cases**
- **Aruba Instant ON Solution**
- **Partner Managed services**
- **Aruba upcoming release**
- **CTA**



# Customer IT Challenges

Complex & costly to upgrade

Outdated equipment



Poor network performance

Too many devices to manage



Hidden costs



Security concerns



# SMALL BUSINESS TRENDS



**68%**

have a focus on investing in replacing outdated IT infrastructure in 2020.<sup>1</sup>



**43%**

plan to use Gigabit Wi-Fi technology vs. 4% currently use 5G technology.<sup>1</sup>



**44%**

plan to use IT automation tools.<sup>1</sup>



**35%**

of the total IT spend would be allocated to Hardware refresh for small businesses<sup>1</sup>



**50%**

of SMBs will adopt a Cloud-First approach when sourcing software, infrastructure, or platforms<sup>2</sup> by 2021.

<sup>1</sup> <https://www.spiceworks.com/marketing/state-of-it/report/>

<sup>2</sup> IDC FutureScape: Worldwide SMB 2020 Predictions

# Small Business Buying Behavior



Willing to deploy out-of-the-box solutions to save money



Limited budgets; lack of dedicated IT

Looking for long-term value for their investment



Simple  
Reliable  
Easy-to-use



Want to ensure the security of their company and customers' data



# Solutions versus Product Pieces



**Become a Trusted  
Advisor**



# Business Results



**Improve productivity**  
**Manage change**  
**Minimize risk**

# TODAY'S SMALL BUSINESS PIVOT



**92%**

Report a reduction in daily demand for goods and services



**50%**

Say Telecommunications and Business Software spending won't be reduced



**78%**

Are currently or plan to transition to digital sales



**87%**

Have moved meetings, events and appointments online



**84%**

of SMBs will pivot to remote IT and access solutions.

1. <https://www.spiceworks.com/marketing/state-of-it/report/>

2 IDC FutureScape: Worldwide SMB 2020 Predictions



A woman with dark hair, wearing a vibrant green top and a long red beaded necklace, is looking down at a smartphone she is holding in her hands. The background is a blurred indoor setting with a brick wall on the left and a window on the right. The overall lighting is soft and focused on the woman.

# ADDRESS SMALL BUSINESS OUTCOMES

## Attract New Customers

Invest in technology to grow revenue and reach new customers

## Gain Competitive Advantage

Adopt digital payment options, provide guest Wi-Fi and more

## Improve Operational Efficiencies

Manage cost to be more efficient and productive



# INTRODUCING THE ARUBA INSTANT ON FAMILY

## INDOOR ACCESS POINTS



**Instant On AP11**  
2x2:2

**Instant On AP12**  
3x3:3

**Instant On AP15**  
4x4:4

## HOSPITALITY ACCESS POINTS



**Instant On AP11D Desk/Wall**  
2x2:2

## OUTDOOR ACCESS POINTS



**Instant On AP17**  
2x2:2

# MANAGEMENT OPTIONS

## INSTANT ON MOBILE APP OR CLOUD-BASED WEB PORTAL

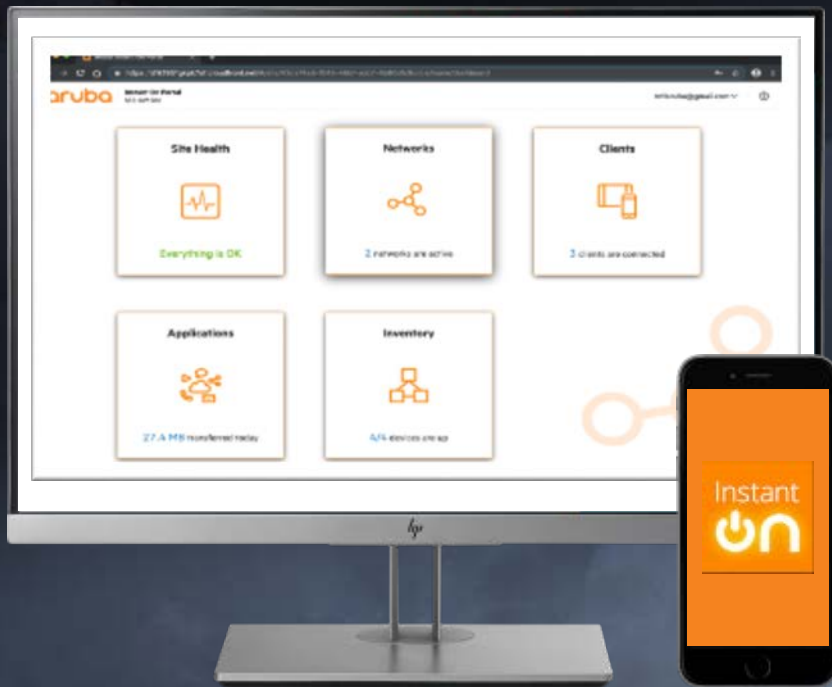

### Smart Mesh Setup

Add additional access points to your network with 1-step mesh set-up



### Future-proof and secure your network

With automatic software updates, your network always remains up-to-date and secure.



### Get a personal view

Whether you are a reseller managing multiple sites or a small retail owner, get a personalized view for all of your locations.



### Manage multiple networks

It sounds difficult, but it's just a simple way of creating separate guest and employee networks.



### Customize your guest portal

Create a custom guest login page to build your brand and make Internet access a breeze.



# We've got you covered!

## Find The Right Fit



**AP11**  
(2x2:2)



**AP11D**  
(2x2:2)



**AP12**  
(3x3:3)



**AP15**  
(4x4:4)



**AP17**  
(2x2:2)

### Ideal Deployments

- SOHO
- Boutiques
- Retail Shops

- Boutique Hotels
- Medical Offices
- SOHO

- Doctor's Offices
- Cafes
- Boutique Hotels
- Restaurants

- Tech Start-ups
- Design Firms
- Professional Offices

- Outdoor Café
- Open Restaurants



# KEY PARTNER BENEFITS



## Growth

Grow your customer base

Expand engagement with new prospects that are looking for a reliable WLAN infrastructure

Easy to recommend – Aruba's simple and reliable high performance connectivity partners can trust



## Increased Revenue

Increased revenue for deploying and managing customer's networks

Attach value-added services for ongoing support



## Build Stronger Relationships

Leverage your IT expertise to grow a managed service provider business

Upsell a complete end-to-end small business network solution- expanding switching footprint

# WHY ARUBA INSTANT ON?



## **Simplicity at its Best**

Hassle-free set-up  
and management

Remote and multi-site  
management: Instant On  
mobile app and Cloud-based  
web portal



## **Best-in-Class Security**

Secure guest and  
employee access

Integrated WPA2/WPA3,  
OWE Wi-Fi security standard  
for secure open networks



## **“Always-On” Network**

Superior software  
hardware quality from a  
trusted vendor

High performance  
Wi-Fi network

Unmatched user  
experience and support





**Simple Wi-Fi setup**

**Aruba's 17 years of proven innovation**

**Manage your network from anywhere**

**Flexible management options**

**Unmatched support experience**



August, 2019



# Instant On

## Ver 1.2 Feature Update



# Agenda

1. Instant On mobile app - 7 new languages
2. DHCP/NAT
3. Bandwidth limiting - per SSID/user
4. Client blocking



# Expanded Mobile App Support

## 7 New Languages

### English plus;

- Chinese (simplified)
- Japanese
- French
- German
- Italian
- Spanish
- Portuguese

### Go Anywhere administration for partners with customers in multiple regions

1. When the app starts, it detects the locale of the phone and sets local language, which is saved and used every time the app launches
2. Saved language is communicated to the cloud and notifications are sent in the same language
3. If the phone's locale is not one of the supported languages, it defaults to English





# Secure Network Segmentation

Built-in DHCP/NAT Support

## IP Address Costs Savings

- Only pay for 1 Static IP Address from Provider
  - No monthly fee for next level addressing (2, 3, 5 addresses)
- Does not require paying for external Gateway (~ \$340 or more savings)
- NAT lets outside world **only** see public address scheme

Easily keep users and device traffic separate

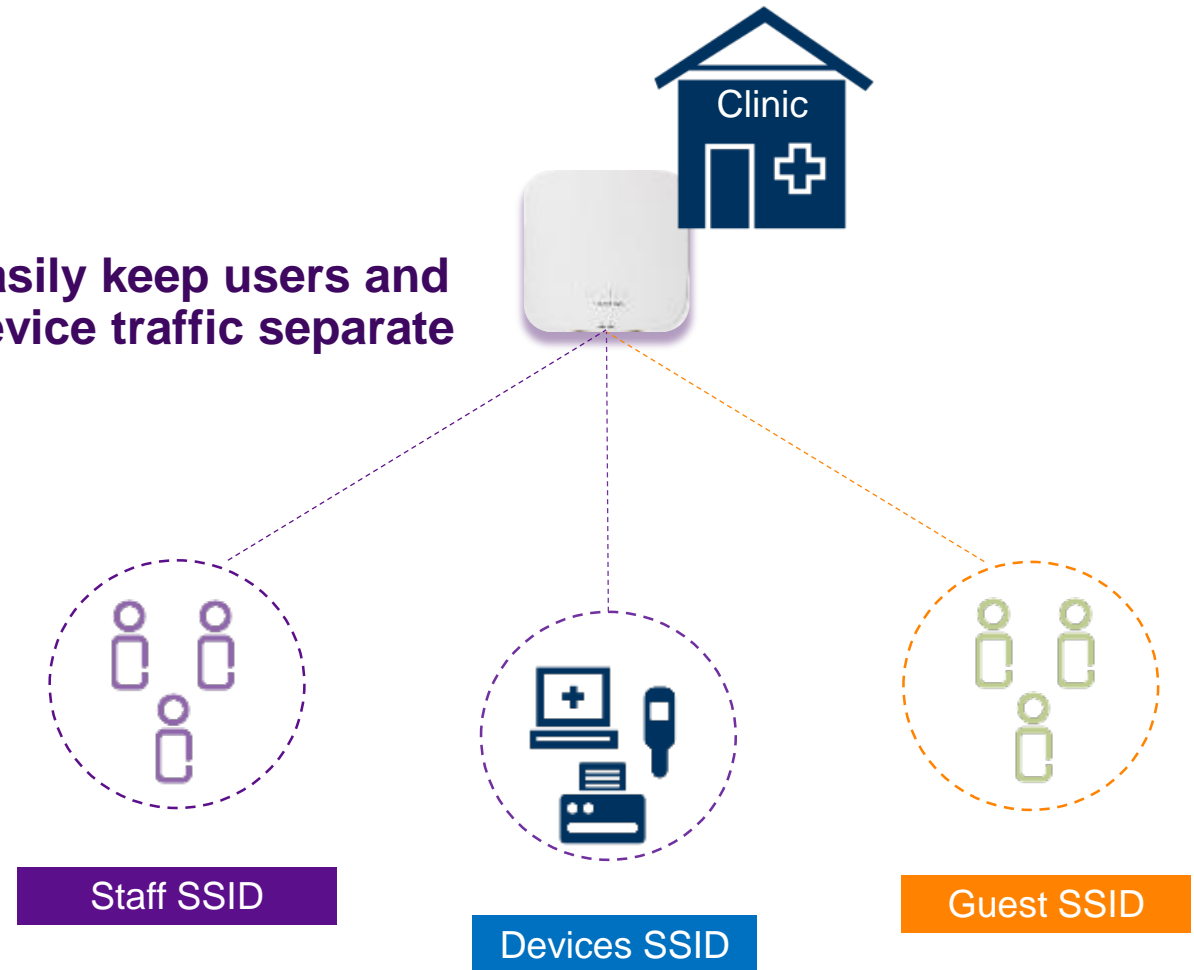

# How it Works - Example

## Built-in DHCP/NAT Support

- Devices on each network has their own address scheme
- Simple to keep different traffic from users/devices secure

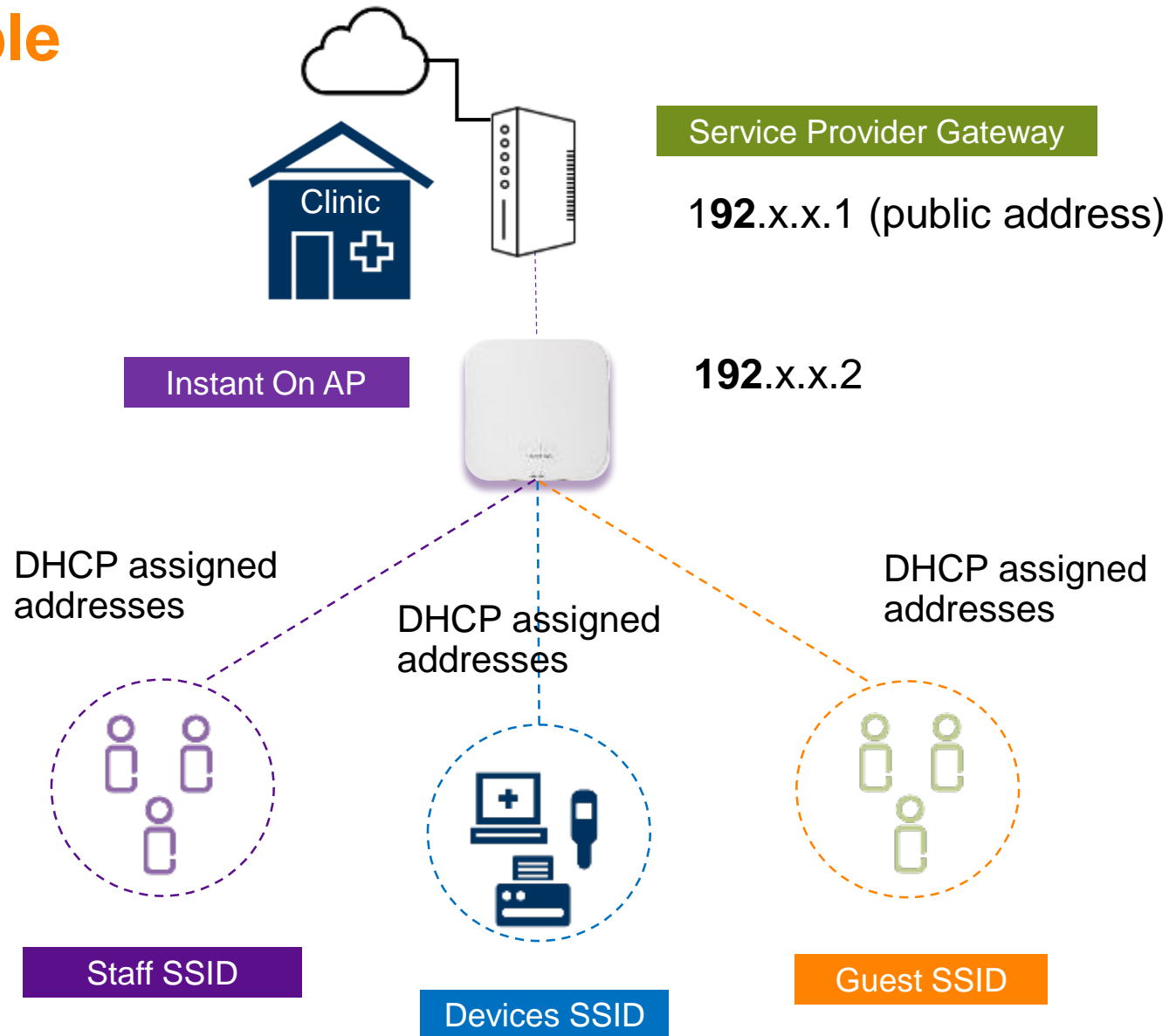



# Per SSID, Per User Rate Limiting

Simple Quality of Service Control

## Control bandwidth use during peak hours

- Limit video bandwidth to 2.5Mbps (720p) per user on an SSID
  - > 4Mbps needed for 1080p HD
  - Day of the week, set hours
- Easy to setup different QoS rate for employee network if needed
- Simple to configure via mobile app or web

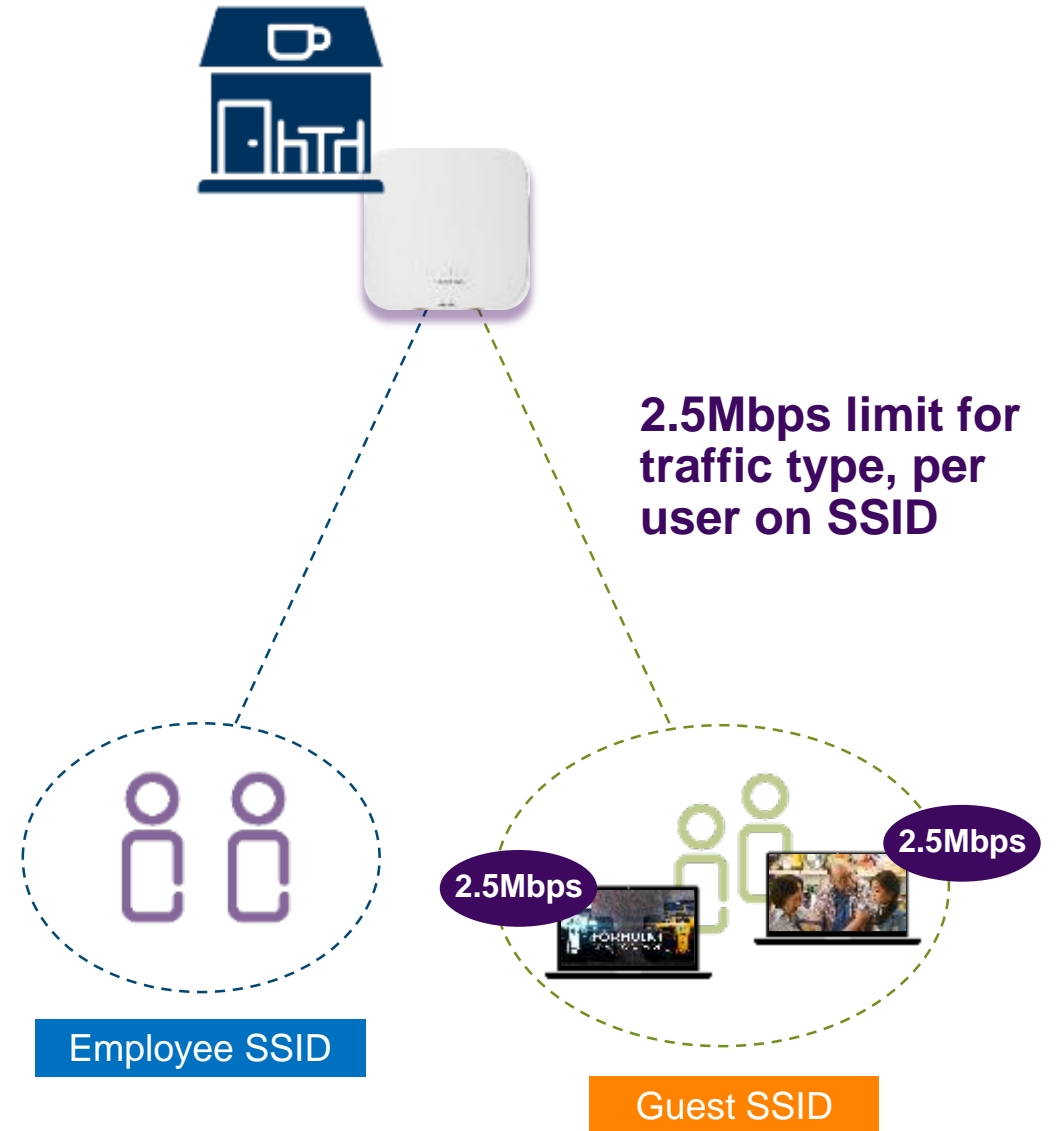

# Client/Device Blocking

Fast and Easy Performance and Security Fix

## Simple MAC address blocking

- Notice user/device using over consuming bandwidth
- Takes minutes to keep person or device from using the network
- Implement via mobile app or web

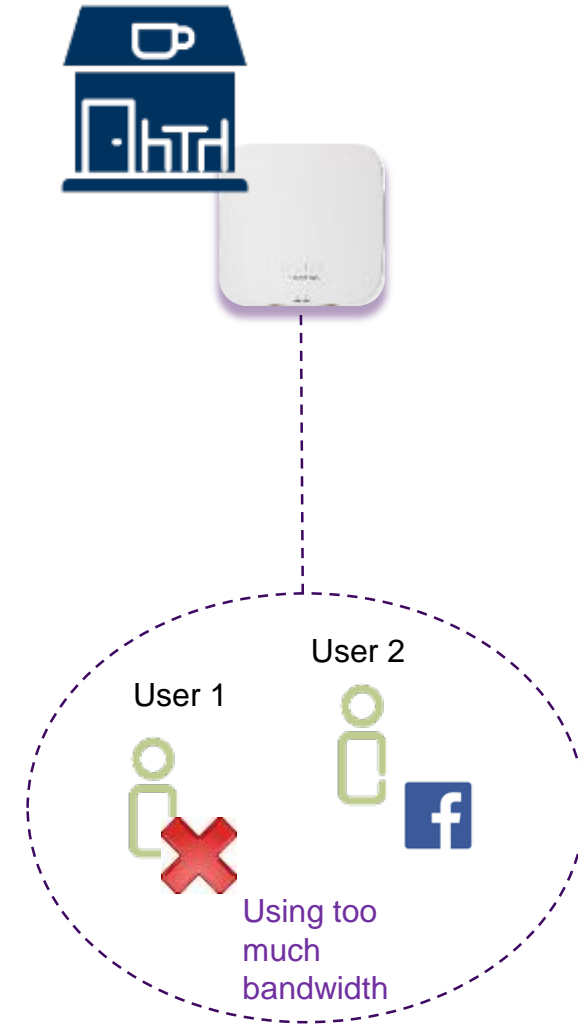



October, 2019



# Instant On

## Ver 1.3 Features Update



# Agenda

1. Integrated gateway and firewall
2. App/web traffic visibility and blocking
3. Support for popular guest Wi-Fi portals
4. Mobile app enhancements
  - Enhanced troubleshooting
  - New installation wizard
  - 2 new languages
5. Automated regulatory table (DRT) updates





# Integrated Router and Firewall

No need for External Devices

**Gateway function lets you connect an AP directly to a modem while automatically blocking traffic initiated from outside**

- Now, the AP can assign DHCP IP addresses and perform NAT for clients, *and* for other wired/mesh APs
- Keeps business computers and IoT devices safer
- Added protection without buying extra hardware or software services
- Rules are pre-built for hassle free security

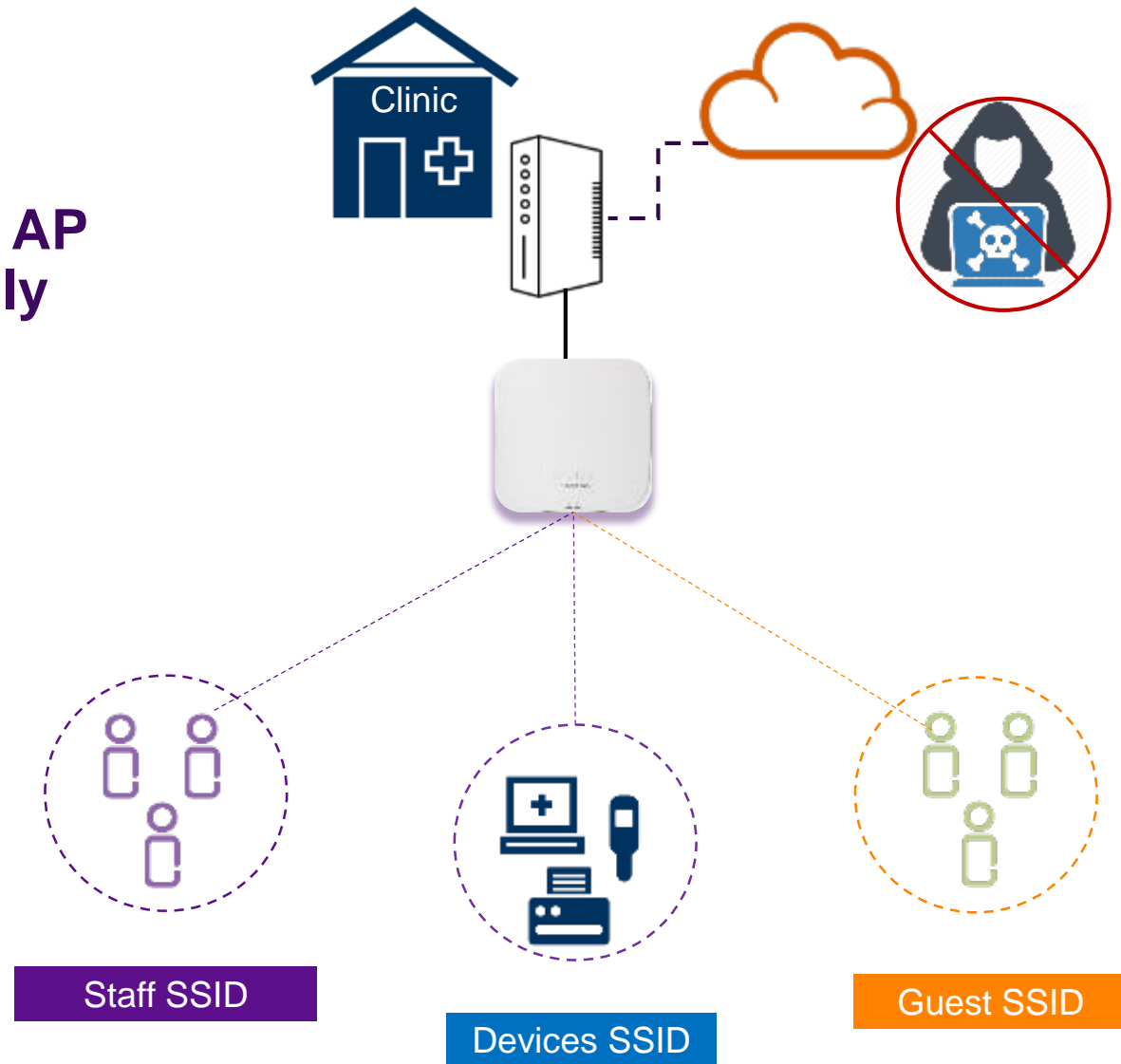

# Traffic Visibility and Blocking

For Apps and Web Traffic Categories

## Spot common apps and filter by network

- Visibility into app and web traffic using integrated deep packet inspection engine
  - Understand resource usage and spot unwanted traffic
- Easily block up to 19 categories of content
  - Sports, adult entertainment, social networks, gaming...
- All without an external firewall, enabling simplicity and cost savings

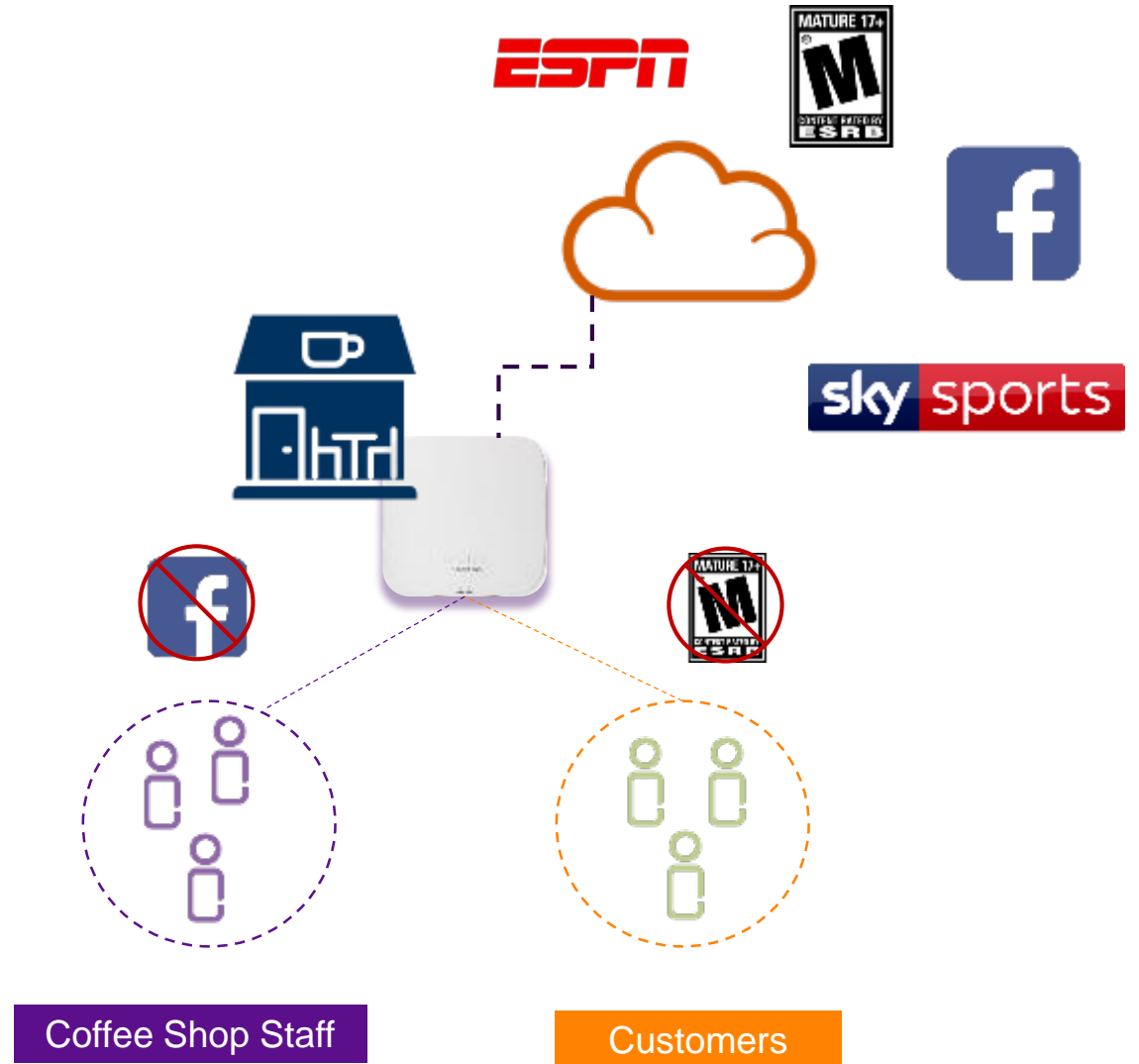



# New Support for Guest Logins

Popular guest access portals and Facebook Wi-Fi

## Easy to use guest portal integration

- Simple login using third-party portals or social logins
- Leverage partner analytics for data on users, behavior and visits
- Facebook Wi-Fi also supported for social logins, likes, and easy guest experience...



# Enhanced Troubleshooting using Bluetooth

No Cabling Required

## APs tell you when there's a problem during initial setup

- I'm not connected to the network
- No IP address, authentication failed, no Internet access
- Mesh AP detected and up
- Works with Instant On Mobile App
- Helps simplify troubleshooting without climbing on a ladder to diagnose
- Unique to Aruba Instant On



# Installation Wizard

Step-by-step installation guidance

No need to look at physical documentation to deploy your network

- Makes it easy for non-Tech staff to deploy Wi-Fi
- Just match your setup to the image in wizard
- Two (2) basic AP modes:
  - **Private Network:** acts as DHCP server for guest clients only
  - **Wi-Fi Router:** provides IP addresses to all other APs

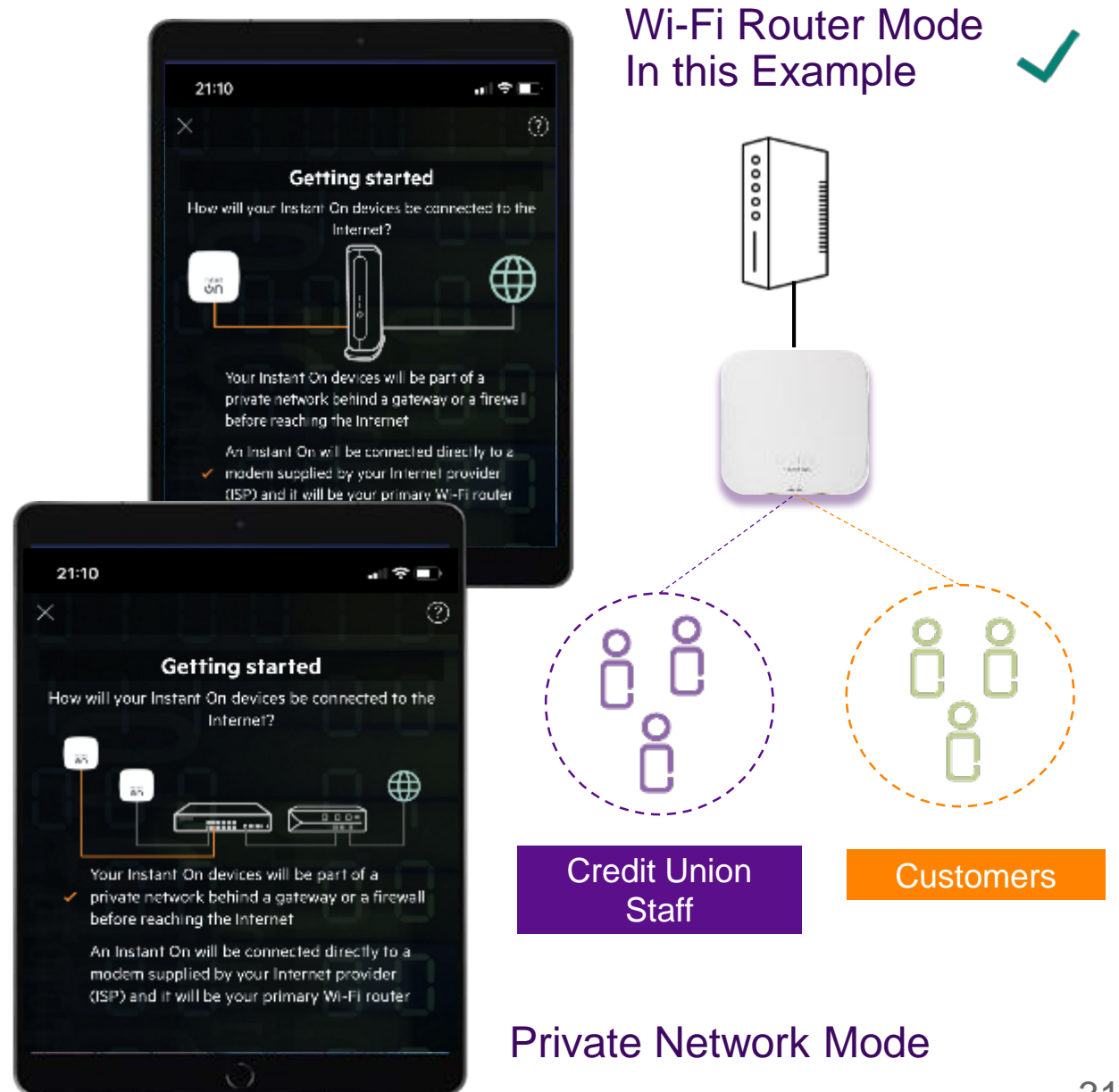



# AP Wired Port Visibility

Built-in Ethernet Ports Just Got Smarter

## Real-time status on how the your ports are working

- Port status (Link up/down)
- Port speed negotiation
- Download and upload speed
- See the status of ports on any AP with Mobile or web
- No need to send someone out to look at LEDs or climb ladders

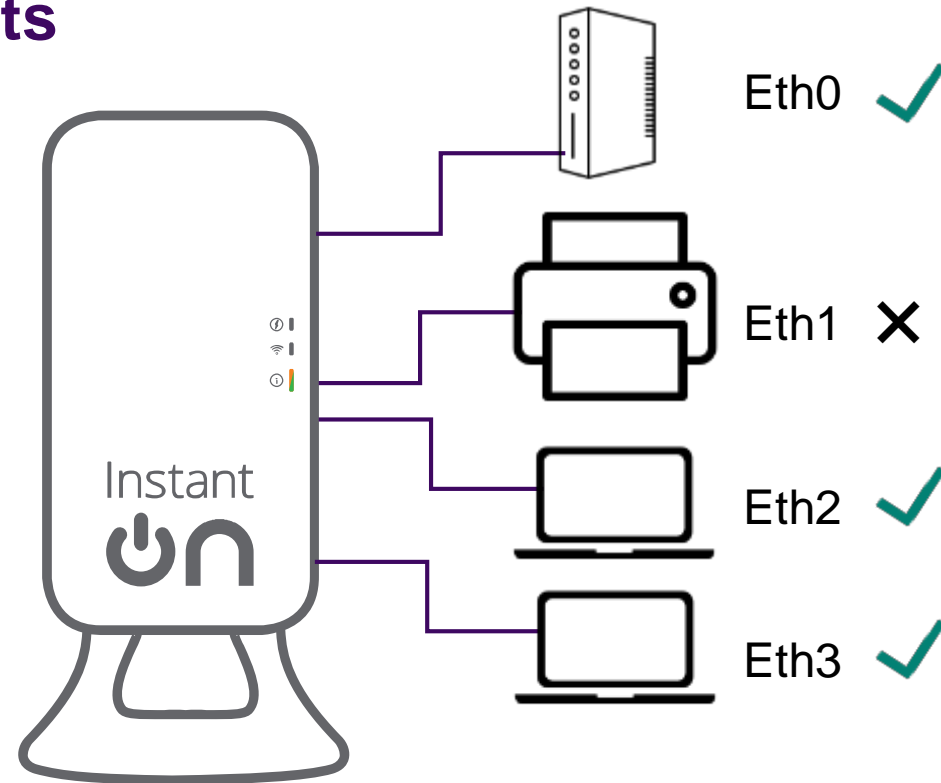

Jan 2020



# Instant On

## Ver 1.4 Features Update



# Agenda

1. PPPoE / static IP settings
2. RF controls:
  - a) Ability to control network band
  - b) Ability to control channel bandwidth
3. Performance improvements (DPI)
4. Open guest network
5. Applications and client visibility enhancements
6. Gateway availability enhancements
7. RADIUS proxy / NAS IP
8. LED quiet mode
9. Features to share internally and with partners





# PPPoE\*

## Assign static IP address to an AP while connecting the AP to the ISP's PPPoE server

- Until now, Instant On Access Points(AP) required DHCP IP only. Now, we can assign a static IP address to the AP
- Instant On APs now support PPPoE. With this, APs can authenticate and get connected to the ISP's PPPoE server using their uplink.
- **How it works?**
- After the AP boots, it will broadcast an SSID InstantOn-AB:CD:EF
- Connect to this SSID and use the web browser and enter the URL <https://connect.arubainstanton.com>. Enter the authentication credentials and you are done

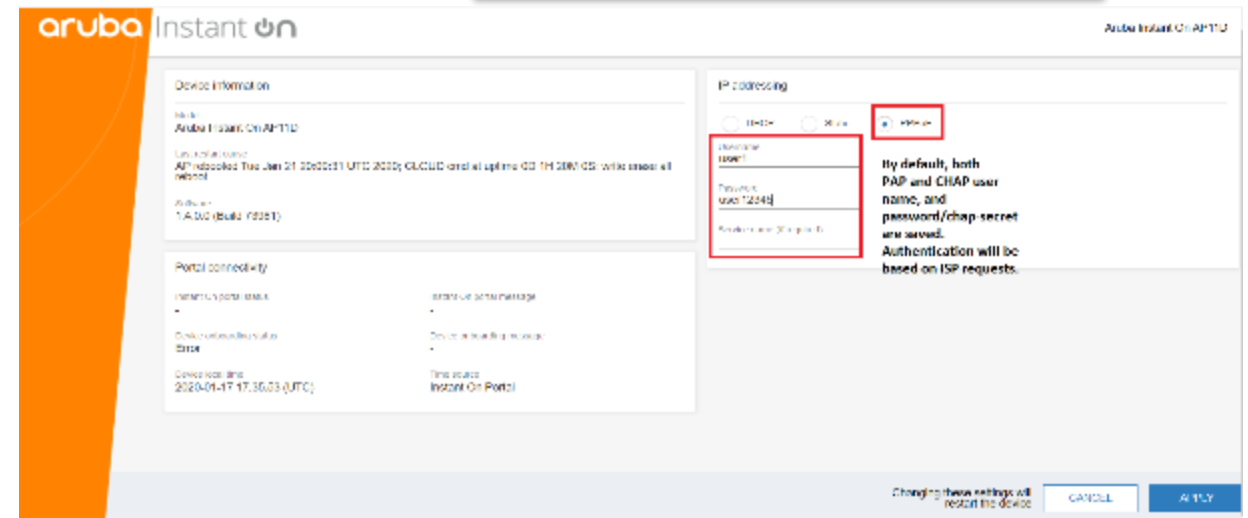
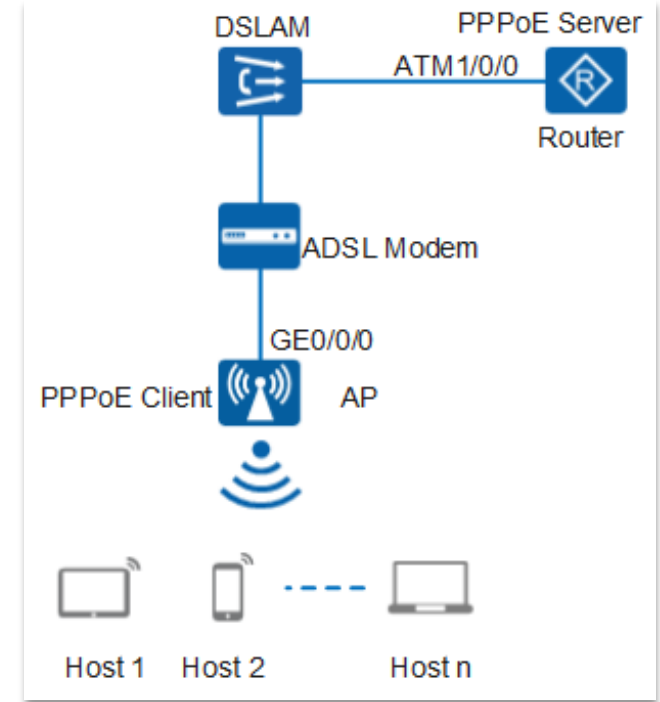

# Key Performance Improvements

## Ability to turn on/off DPI

### Under Visibility and Control, there are two options

- Application details shows all apps used (turns DPI on)
  - Application activity summary disables DPI (no visibility into used apps)
  - Improves throughput of the AP in high density environments
- Instant On APs have DPI and FW functionality built-in which is a huge value add.
- Competitors like Ubiquiti and others do this on a separate GW/FW and charge extra
- DPI impacts performance. This feature is primarily for customers who prefer performance over DPI:
- We now have an option to turn off DPI which potentially increases throughput on the AP

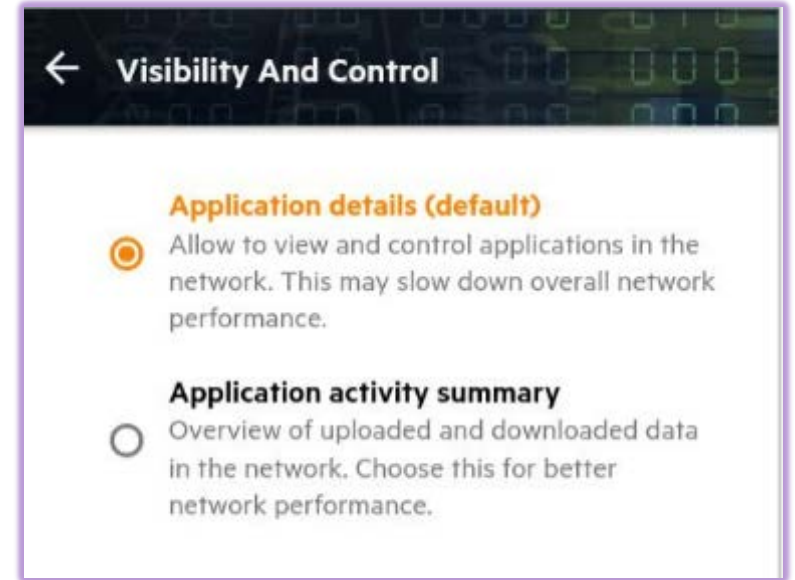

# Open Guest Network

- This is the ability to have an open guest network without Captive portal or PSK
- Guests will now be able to directly connect to the Wi-Fi without entering any details or going through additional steps
- **Customer benefit**
- Simplified guest onboarding experience as config for the admin

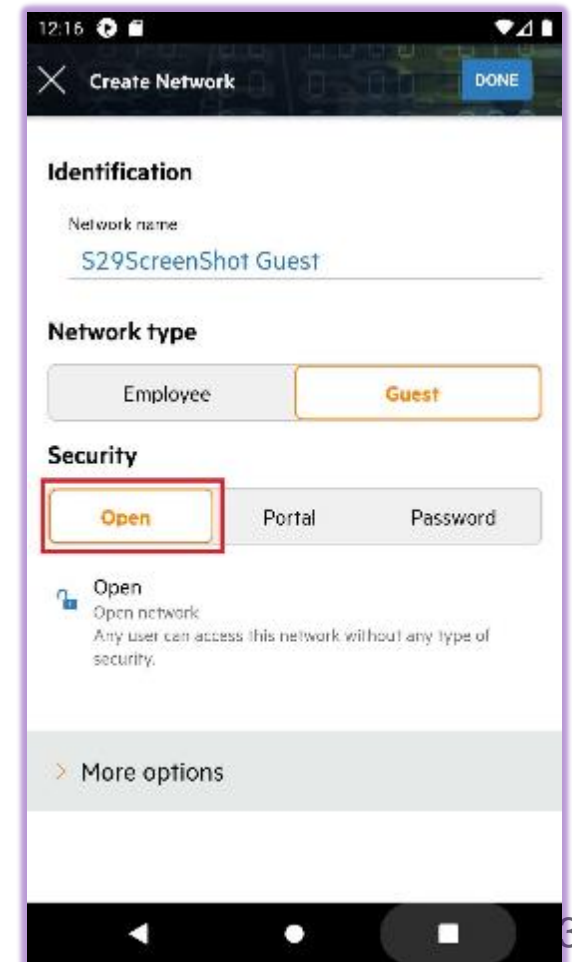



Jan 2020



# Instant On

## Ver 2.0 Features Update



## Remote VPN Solutions

### Secure, Affordable Remote VPN For Home and Business Use

- NordVPN is a trusted online VPN provider that powers >12 million users worldwide.
- Ideal for Instant On users because of a focus on simplicity, security, and value-based pricing.
- The joint solution offers many unique added-value capabilities:
  - Works with any sized Aruba Instant On deployment, anywhere in the world, from a single access point in a home to a medium sized business;
  - Discounted pricing when ordered via the Instant On app;
  - 256-bit AES encryption, no tracking of visited sites, and high throughput for streaming;
  - Optional ad blocking;
  - Can be added at any time – does not have to be commissioned at the time of deployment;
  - Multiple subscription plans from one month to multi-year.



# External Captive Portal

- Captive portal vendor selection on dashboard
- Pre-populate details for the 4 vendors – tight integration
- Customer benefit
  - Free features on Captive portal with Instant On
  - Easy integration with captive portal
  - High ROI, customer loyalty, advanced analytics and marketing capabilities to improve business
  - For Partner managed service, Partner can buy a pool of licenses and have the ability to manage all their customers





# Aruba Instant On & Aislelabs

## Transform Guest Wi-Fi into a Powerful Marketing Tool

- The joint solution offers many unique added-value capabilities:
  - Measures the return on investment of each campaign by linking on-line and off-line sales to specific marketing programs;
  - Support for custom integration with CRMs (Salesforce, Oracle, and others) and third-party business applications;
  - Global 24-7 support with regional offices in North America, UK, Middle East, and India;
  - Dedicated Customer Success team with expertise in deploying the joint solution across different vertical applications.



FREE TIER FEATURES	PREMIUM TIER FEATURES
<p>Authentication</p> <ul style="list-style-type: none"> <li>• Facebook<sup>®</sup></li> <li>• Instagram<sup>®</sup></li> <li>• Twitter<sup>®</sup></li> <li>• LinkedIn<sup>®</sup></li> <li>• E-mail login</li> </ul>	<p>Free Tier features plus:</p> <p>Advanced marketing</p> <ul style="list-style-type: none"> <li>• Full featured e-mail marketing</li> <li>• Unlimited e-mails with no extra cost</li> <li>• Built-in social (Facebook/Instagram) advertising</li> <li>• Feature rich automated email campaign options, based on visit history, frequency of visits and/or demographic information</li> <li>• Numerous “set and forget” pre-built campaigns to fully automate your digital marketing efforts</li> <li>• Built-in smart coupons to engage loyal and at-risk customers</li> <li>• Smart Reviews features to increase positive user ratings of your venue on sites such as TripAdvisor<sup>®</sup>/Yelp<sup>®</sup>/Zomato<sup>®</sup>/Google Local<sup>®</sup>/Facebook Local<sup>®</sup></li> <li>• Integration with digital-ad platforms to externalize all collected data</li> <li>• Enable location based digital campaigns using the customer profiles and visit history natively through the Aislelabs solution</li> <li>• Full-featured SMS campaigns with location based triggers (additional SMS costs apply)</li> </ul>
<p>Basic customizable captive portal</p> <ul style="list-style-type: none"> <li>• Multilingual support (170 languages)</li> </ul>	<p>Visitor details:</p> <ul style="list-style-type: none"> <li>• Unlimited collection and storage of detailed customer profiles and customer history</li> <li>• Customizable, location-based surveys to obtain real-time visitor feedback per venue</li> <li>• Unlimited CSV exports and API access</li> </ul>
<p>User details</p> <ul style="list-style-type: none"> <li>• Aggregated reports</li> <li>• Limited access to user profiles (view 10 recent user profiles)</li> </ul>	<ul style="list-style-type: none"> <li>• Customized reporting and advanced analytics</li> <li>• Premium onboarding and account management support</li> </ul>

# Aruba Instant On & Purple

## Give Guests the Ultimate Wi-Fi Experience

### – UNIQUE VALUE PROPOSITION

- The joint solution offers many unique added-value capabilities:
- Highly customizable custom journeys;
- Global 24-7 support in both Spanish and English;
- Dedicated pre-and-post-sale Customer Care team.





FREE TIER FEATURES	PREMIUM TIER FEATURES
<p>Authentication</p> <ul style="list-style-type: none"> <li>• WeChat<sup>®</sup></li> <li>• Facebook<sup>®</sup></li> <li>• Instagram<sup>®</sup></li> <li>• Twitter<sup>®</sup></li> <li>• Form<sup>®</sup></li> <li>• V Kontakte<sup>®</sup></li> <li>• E-mail login</li> </ul>	<p>Free tier features plus:</p> <p>Advanced customizable captive portal</p> <ul style="list-style-type: none"> <li>• Ability to add custom terms and conditions to the login journey</li> <li>• Ability to use your own designs for your HTML splash pages</li> </ul> <p>Advanced marketing</p> <ul style="list-style-type: none"> <li>• Access your own marketing customer relationship management (CRM) system</li> <li>• Create and schedule marketing campaigns to your customers via SMS or e-mail</li> </ul>
<p>Basic customizable captive portal</p> <ul style="list-style-type: none"> <li>• Multilingual support</li> <li>• User access journeys</li> </ul>	<p>Analytics</p> <ul style="list-style-type: none"> <li>• Enhanced analytics</li> <li>• Custom, user-created dashboards</li> </ul>
<p>User details</p> <ul style="list-style-type: none"> <li>• Basic dashboard</li> </ul>	<p>Reports</p> <ul style="list-style-type: none"> <li>• ‘My Reports’ feature creates and saves reports that you find most useful</li> <li>• ‘Scheduled Reports’ sends reports automatically via e-mail</li> </ul>

# Aruba Instant On & Skyfii

## Leverage Wi-Fi Networks as a Powerful Channel for Growing Business

- The joint solution offers many unique added-value capabilities:
  - Integrations with a wide range of data sources including point-of-sale, staffing, cameras, social, Web, and weather;
  - A Professional Services team to assist with marketing campaign planning and design, digital strategy, and extracting the deepest insights from customer data;
  - Teams in eight countries covering all geographical regions.



FREE TIER FEATURES	PREMIUM TIER FEATURES
<p>Authentication</p> <ul style="list-style-type: none"> <li>• Facebook®</li> <li>• Instagram®</li> <li>• Twitter®</li> <li>• E-mail login</li> <li>• LinkedIn®</li> </ul>	<p>Free tier features plus:</p> <p>Authentication</p> <ul style="list-style-type: none"> <li>• SMS log-in</li> </ul> <p>Advanced marketing</p> <ul style="list-style-type: none"> <li>• Captive portal content targeting</li> <li>• Multichannel customer relationship management (CRM) including e-mail, SMS, or mobile push notification</li> <li>• API and CRM integration using Skyfii's simple REST API or by direct integration into most major CRM platforms</li> <li>• Campaign automation</li> <li>• Campaign attribution and redemption including integration with point-of-sale (POS) systems</li> <li>• Loyalty program integration</li> </ul>
<p>Basic customizable captive portal</p> <ul style="list-style-type: none"> <li>• User Experience Designer</li> <li>• Multilingual support (18 languages)</li> <li>• Show or hide captive portal content based on time of day or day of week</li> </ul>	<p>Advanced customizable captive portal</p> <ul style="list-style-type: none"> <li>• Captive portal survey design and integration</li> <li>• Video and advertising overlays</li> <li>• Test and optimize multiple variations of captive portal design to convert the highest volume of guests</li> </ul>
<p>E-mail marketing using basic segments (limit 500 subscribers)</p> <p>User details</p> <ul style="list-style-type: none"> <li>• Visitor profile using attributes from social media login</li> <li>• Real-time and historical analytics of Wi-Fi usage patterns</li> </ul> <p>Limit of three access points per site, and three sites per account</p>	<p>Analytics</p> <ul style="list-style-type: none"> <li>• Multi-data source integration</li> </ul>



# Aruba Instant On & Wavespot

## Grow Sales with Location Based Marketing & Insights

- The joint solution offers many unique added-value capabilities:
  - Marketing services and guest pass authentication are included in the free tier;
  - Integrated with leading point-of-sale (POS), customer relationship management (CRM), and loyalty solutions;
  - Sales across 130 countries and support for multiple languages;
  - Dedicated Account team to assist with captive portal marketing programs and provides support services.



FREE TIER FEATURES	PREMIUM TIER FEATURES
<p>Authentication</p> <ul style="list-style-type: none"> <li>• WeChat<sup>®</sup></li> <li>• E-mail login</li> </ul> <p>Basic customizable captive portal</p> <ul style="list-style-type: none"> <li>• Guest pass authentication: generated token based guest access</li> <li>• Multilingual support</li> </ul>	<p>Free tier features plus:</p> <p>Authentication:</p> <ul style="list-style-type: none"> <li>• Twitter<sup>®</sup></li> <li>• LinkedIn<sup>®</sup></li> <li>• Facebook<sup>®</sup></li> <li>• SMS login</li> </ul> <p>Advanced customizable captive portal</p> <ul style="list-style-type: none"> <li>• Drag &amp; drop captive portal builder &amp; workflow, custom splash pages</li> <li>• Voucher and subscription plan authentication</li> </ul>
<p>Single administrator</p> <p>Basic marketing</p> <ul style="list-style-type: none"> <li>• Limited email marketing (500) subscribers)</li> <li>• Limited Wi-Fi marketing (1 marketing message/month)</li> </ul>	<p>Analytics</p> <ul style="list-style-type: none"> <li>• Suite of impression, session and user analytics</li> <li>• Competitor analysis to show how competitors are performing</li> </ul> <p>Robust marketing automation</p> <ul style="list-style-type: none"> <li>• Wi-Fi, e-mail, and SMS marketing</li> </ul>
<p>User details</p> <ul style="list-style-type: none"> <li>• Last login time</li> <li>• 1 day historical data</li> </ul>	<p>Account management and 24/7 support</p> <p>POS integrations for closed loop marketing and payment insights</p> <p>Real-time and historical reports</p>



# VERTICAL USE CASES



**VERTICAL USE CASES**  
**WORKING**  
**FROM HOME**

Whether you're running video conference calls or streaming videos for your kids – you need a reliable network.

The Instant On solution prioritizes business-critical applications, so your work apps come first. The solution also comes with an integrated firewall to keep you and your family's personal information, devices, and network protected from online threats.



# Work From Home Requirements

**Reliable Wi-Fi solution**

**Secured Wi-Fi access**

**Auto prioritization for voice/video conferencing**

**Automatic rf optimization**

**Multiple WLANs for home/office**

**Parental control, ability to block web content**

**Connectivity for wired devices, printers, phones, security cameras**

**Ability to support streaming, audio video content**

**Mesh Wi-Fi**

**Restrict Wi-Fi access outside of business hours**

**Minimal hardware in the closet**



# Parental Controls

## Feature

### Deep Packet Inspection (DPI) Engine

- Visibility into application and website categories
- Ability to block one or more traffic types

### Prioritize Conferencing

- Automatic prioritization for voice/video traffic

### Bandwidth & Time Limiting

- Limit the bandwidth for specific SSIDs
- Time of the day SSID Limiting

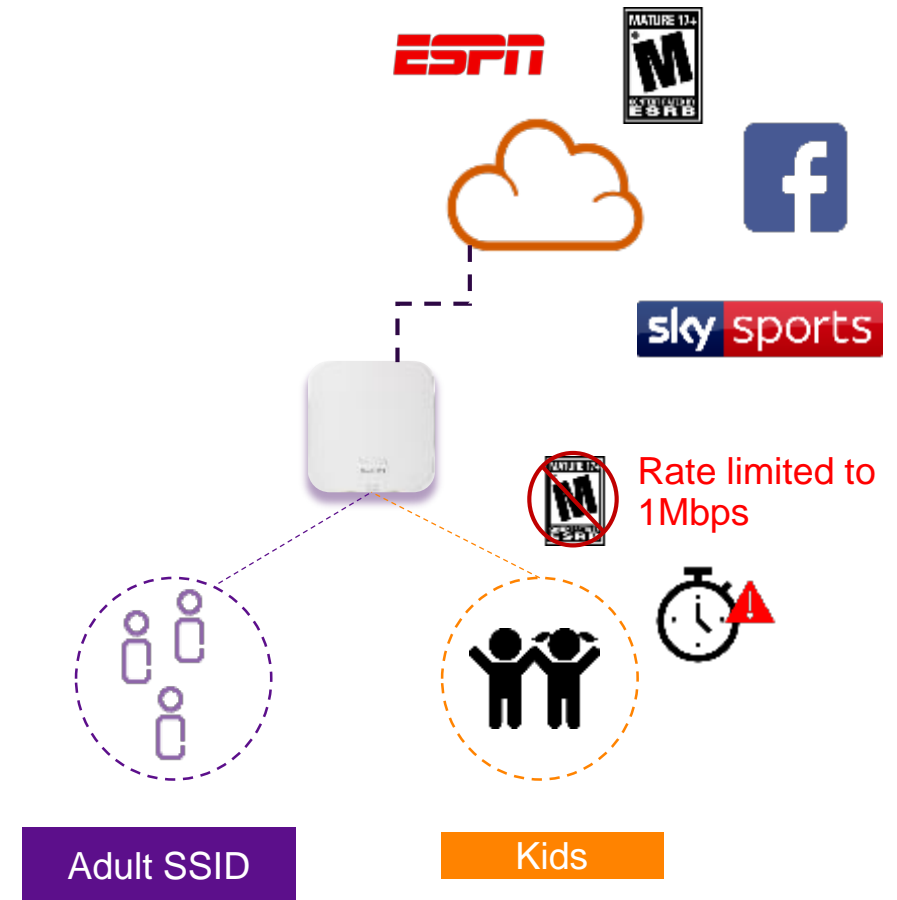

# Enhanced Wi-Fi Security Feature

## Enhanced Wi-Fi Security

- Better security for wireless clients using WPA2, WPA3 security standards

## Client Blocking

- Wireless devices can be blacklisted
- User device can be removed the network
- Block/Unblock Client Devices



Example deployment

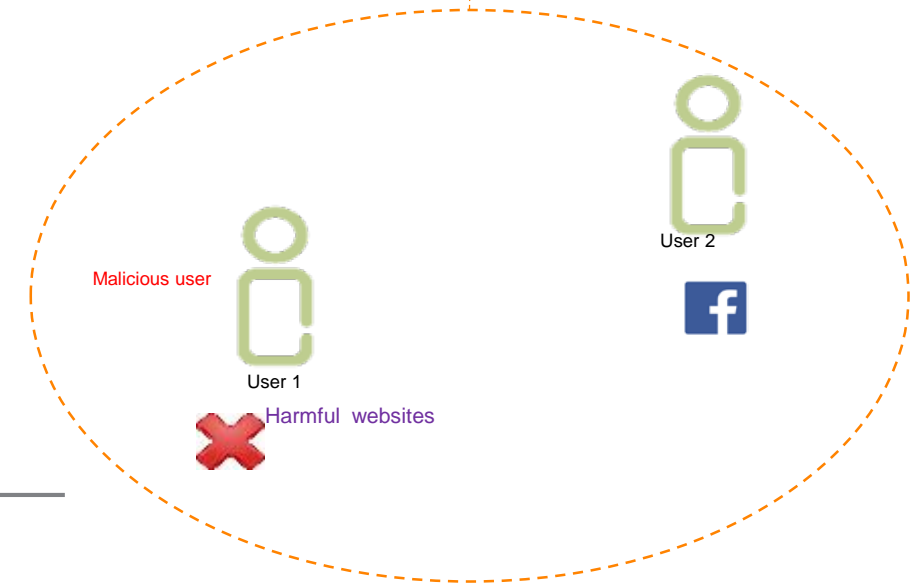

# Enterprise-Grade RF

## Feature

---

### Mesh

- One-click Setup
- Great coverage throughout the home

---

### Dynamic RF Optimization

- Automatic selection of channels and power levels





# Gateway

## Feature

### Block Unsolicited Traffic

- Reliable Built-in firewall
- Block unwanted or unsolicited Internet traffic
- Keep malicious hackers at bay

### Router Mode

- Enables features like routing, DHCP, NAT
- No extra hardware required
- Easy swap of GW

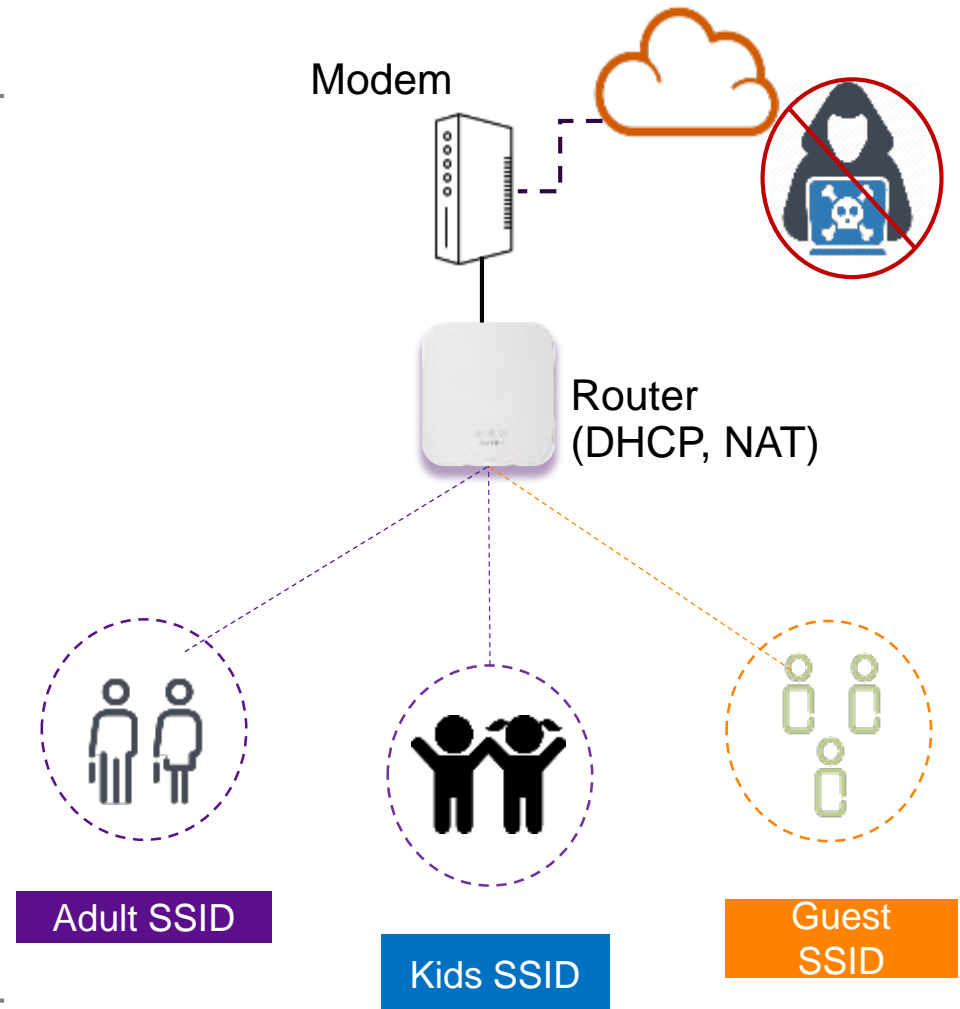

# Deployment example

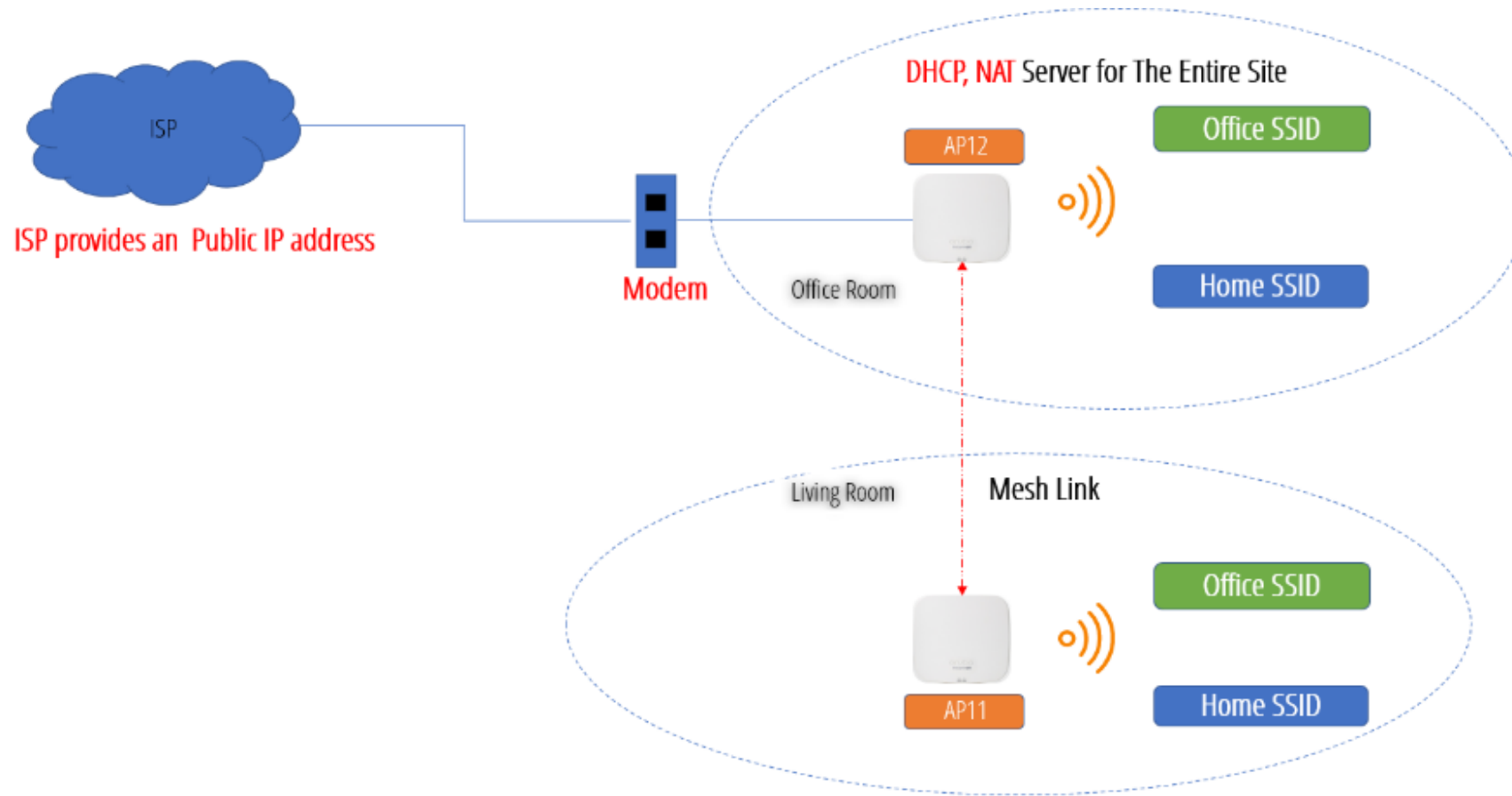

## VERTICAL USE CASES

# CAFES/ RESTAURANTS/ RETAIL

One solution covers inside and the outdoor patio areas. Mobile PoS systems and other IoT can be put on separate network from workers and guests. Can be managed by a service.

Customers enjoy fast ordering and the ability to pay without standing in lines. Cafes want to create an amazing experience for their visitors: guest Wi-Fi, background music, etc.



# Quick Scenario: Restaurant or cafe



## Focus on the business area

- Simplicity
- Ability to grow with the business
- Customer experience







## VERTICAL USE CASES **MEDICAL OFFICE**

Doctor and Dental Offices can better secure health information and offer patients stress free Internet access. Medical devices and records are kept separate from unwanted internal and external access.

A no-fuss firewall keeps pry eyes away. Guest access can be automatically turned off during off hours.

# Quick Scenario: Medical Clinic



## Focus on the business area

- Best-in-class security
- Medical records are safe
- Peace of mind



A young woman with dark hair, wearing large black headphones, is looking down at a laptop screen. She is wearing a grey t-shirt. The background is a dimly lit room, possibly a home office or study. The image is framed with a dark, curved border on the right side.

## VERTICAL USE CASES **ONLINE LEARNING**

Enable high quality and secure digital experiences for teachers and faculty who are supporting students from home.

Students still need to interact with faculty members and may need access to specialized software, previously only available in lab environments.

# Aruba Instant On

## Partner managed services



# Multiple admin access for Management

*Whether a reseller managing multiple sites or small biz owner, you see what's important to you.*

## Multiple login accounts:

- Partner account : Access to all customer sites
- Customer account : Access only to their own site

## Visibility:

- View all your sites at a glance
- Single pane of glass
- 24 hours visibility into the details of all clients

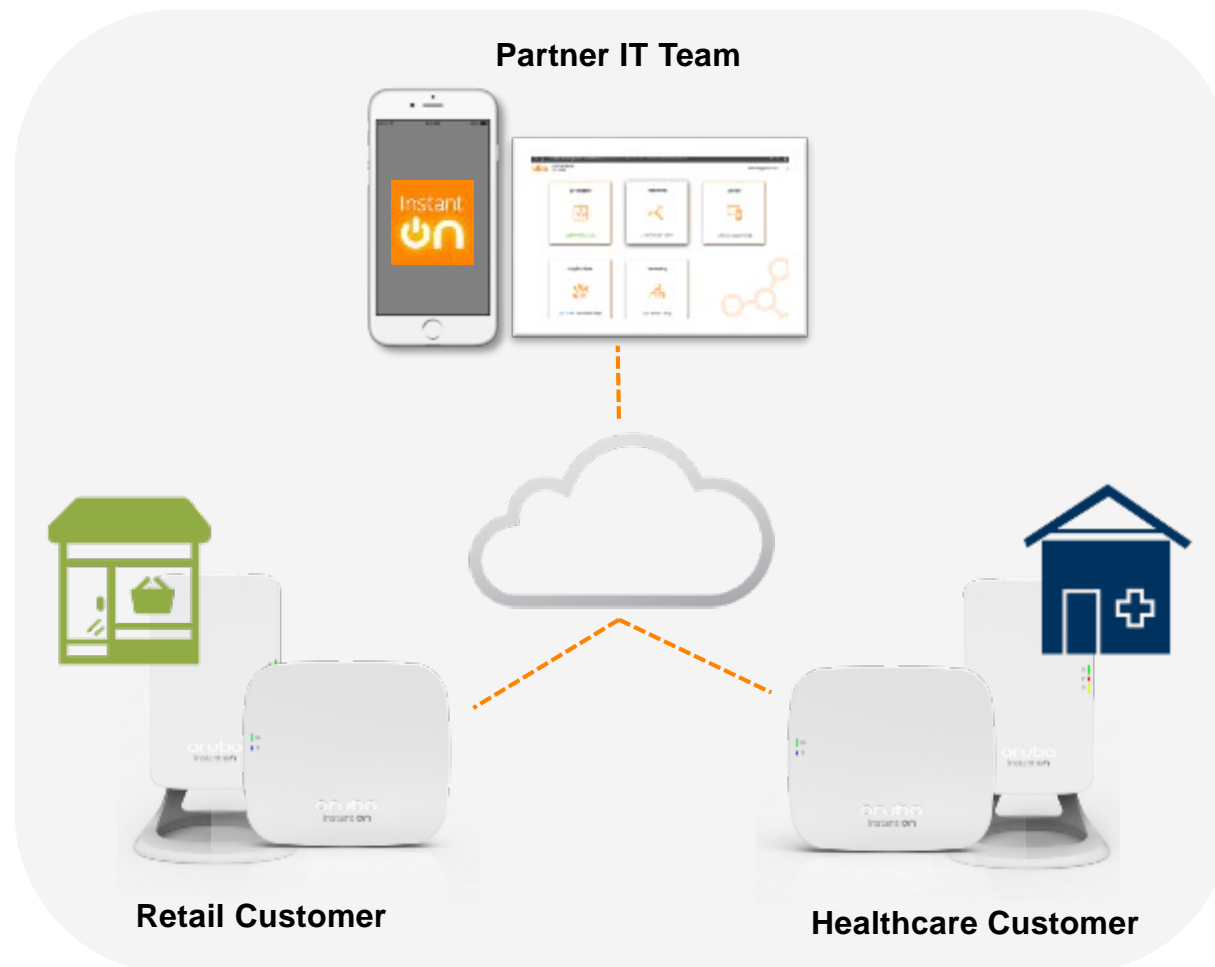

## Multiple sites:

- Each customer site can be managed separately

## Additional services:

- Security – RADIUS authentication, WPA3
- External Captive portal integration

# Remote Multi-site Management

## Peace of mind

- Manage your network from anywhere.
- If you have multiple customers, view all their sites through a single pane of glass - mobile app or web portal (feature parity on both)
- Real time alerts to alert you incase one of your networks has a problem in the form of push notifications

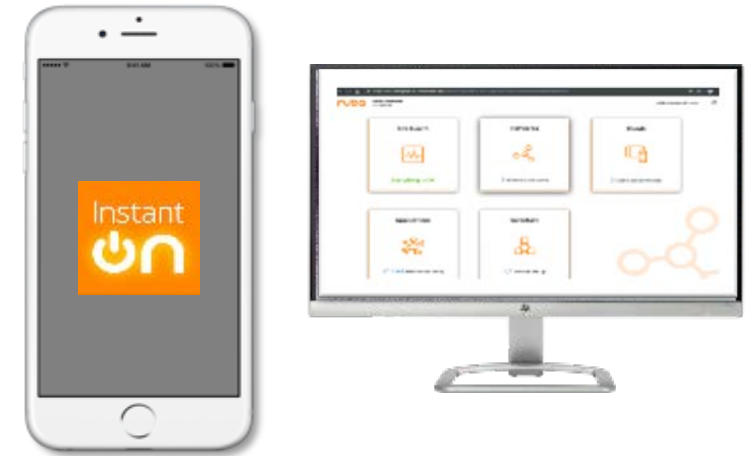

## Support of multiple languages

- Korean
- Chinese (traditional)
- Chinese (simplified)
- Japanese
- French
- German
- Italian
- Spanish
- Portuguese

<customer-email>.com →

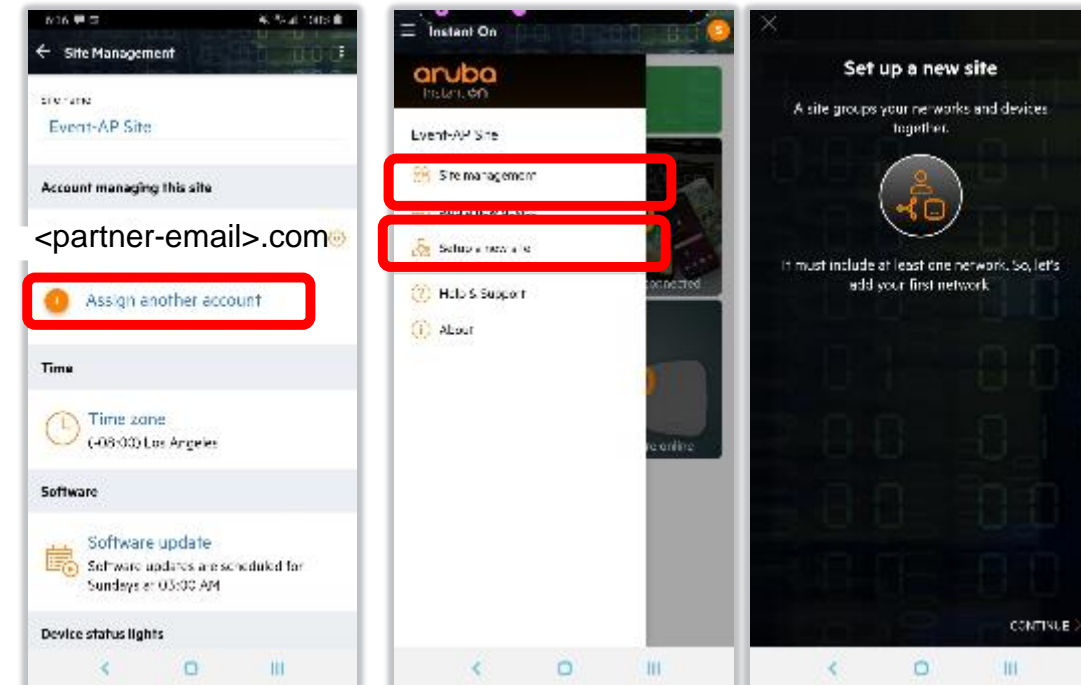

# Partner can provide enhanced Enterprise-grade security

- Better security for wireless clients using WPA2, WPA3 security standards
- External RADIUS authentication:
  - **Partner can setup a RADIUS server and offer advanced 802.1x security to all customers as a value added service**

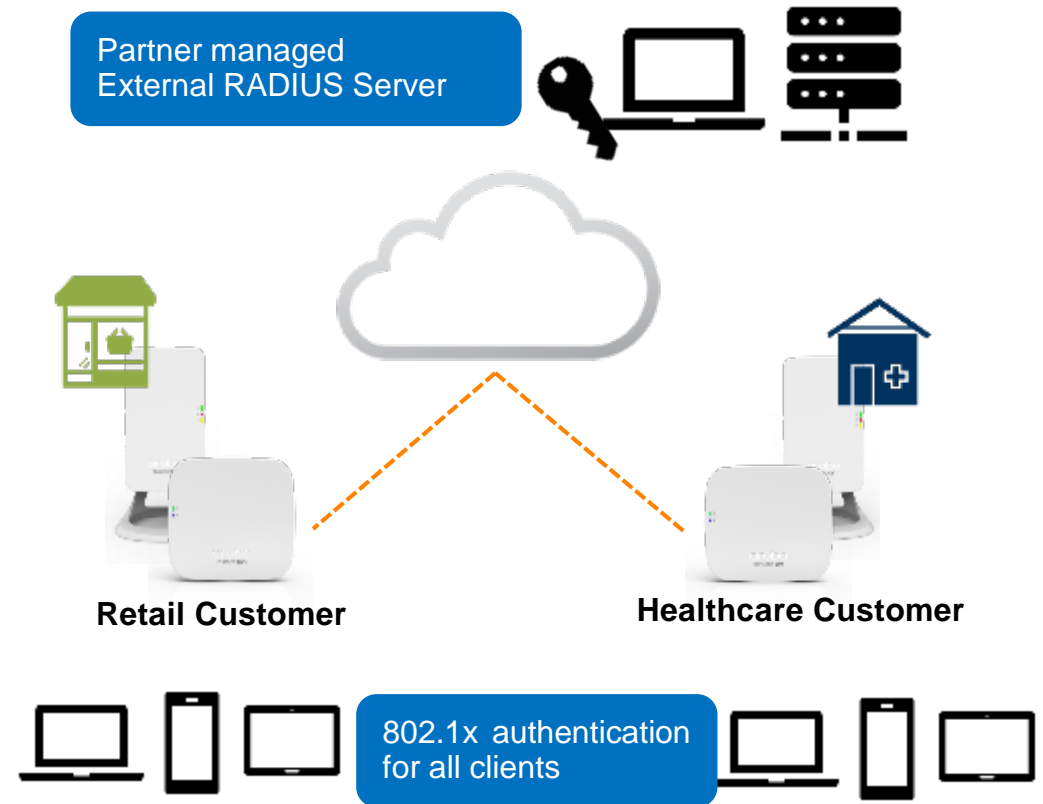

# Single captive portal for Multi-customer deployments

- Aruba Instant On has technology partnerships with major captive portal vendors
- Many advanced features come as part of the free tier with Instant On.
- Partners can also upgrade to advanced tier to avail many more features
- Single pane of glass:
  - **Partner can setup the Captive portal dashboard and use the same dashboard to view all the customer sites.**
  - **Partner can compare data analytics for all your sites/customer stores**



- Popular guest access portals and Facebook Wi-Fi



# Use cases for Instant On and captive portal partnership

## Captive Portal Opportunities for Partners:

- Run targeted marketing/campaigns for select stores
- Increase customer loyalty, ROI and business.
- Connect the POS devices in the store to the captive portal to monitor and compare profits and revenue from each store
- Example: Re-target customers that attend some stores, send coupons so that these customers visit a less popular store
- Example: Check typical age and demographics information for each one of the customer stores to determine what would sell best in each store

# Key Values



## Plug 'n play simplicity

Hassle-free mobile and web-based management



## Best-in-class security

Built-in firewall, DPI and WPA3 next-gen security



## Always-on network

Unmatched, high performance Wi-Fi network

# A Price Point That Fits



No subscription costs

No licensing fees

No additional appliances

Lower TCO



## What to do next....

- Get an Aruba Instant ON AP and try it out .Work with your local Aruba contacts to build Aruba Instant On solution.
- Drive activities with your customer base – running a local webinar, telemarketing/ emailers and social media activity. Contact Aruba marketing team for assets – all you need to do co-brand it
- If you have e-commerce sites then start drive Aruba Instant Solution
- Drive Aruba Instant ON solution !!!!







Q&A





aruba  
Instant on

**THANK YOU**